



±80V Fault-Protected/Tolerant CAN Transceivers for In-Car Applications

MAX3054/MAX3055/MAX3056

General Description

The MAX3054/MAX3055/MAX3056 are interfaces between the protocol controller and the physical wires of the bus lines in a controller area network (CAN). The devices provide differential transmit capability and switch to single-wire mode if certain fault conditions occur. The MAX3054/MAX3055/MAX3056 guarantee full wake-up capability during failure modes.

The extended fault-protected voltage range of CANH and CANL bus lines of ±80V allows for use in 42V automotive applications. Current-limiting and thermal-protection circuits protect the transmitter output stage against overcurrent faults to prevent destruction of the transmitter output stage. The CANH and CANL lines are also protected against electrical transients that may occur in an automotive environment.

The transceiver provides three low-power modes that can be entered and exited through pins STB and EN. An output INH pin can be used for deactivation of an external voltage regulator.

The MAX3054/MAX3055/MAX3056 are designed to provide optimal operation for a specified data rate. The MAX3054 is ideal for high data rates of 250kbps. The MAX3055 is used for data rates of 125kbps and the MAX3056 is designed for 40kbps applications. For the 40kbps and 125kbps versions, a built-in slope-control feature allows the use of unshielded cables, and receiver input filters guarantee high noise immunity.

Applications

Automotive

Typical Operating Circuit

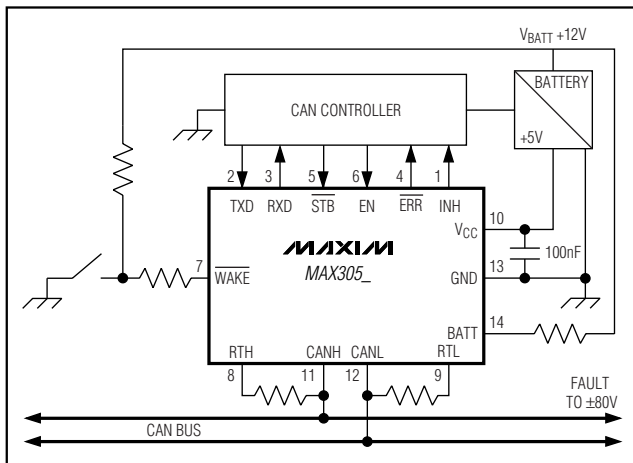

Features

- ◆ Pin and Functionally Compatible with TJA1054
- ◆ ±80V Fault Protection Suitable for 42V Battery Systems
- ◆ Low RFI/Excellent EMC Immunity
- ◆ Full Wake-Up Capability During Failure Modes
- ◆ Bus-Failure Management
- ◆ Support Single-Wire Transmission Mode with Ground Offset Voltages Up to 1.5V
- ◆ Thermally Protected
- ◆ Do Not Disturb the Bus Line when Unpowered
- ◆ Low-Current Sleep and Standby Mode with Wake-Up Through Bus Lines
- ◆ Up to 250kbps Data Rate (MAX3054)

Ordering Information

PART	TEMP RANGE	DATA RATE	PIN-PACKAGE
MAX3054ASD	-40°C to +125°C	250kbps	14 SO
MAX3055ASD	-40°C to +125°C	Slew control 125kbps	14 SO
MAX3056ASD	-40°C to +125°C	Slew control 40kbps	14 SO

Pin Configuration

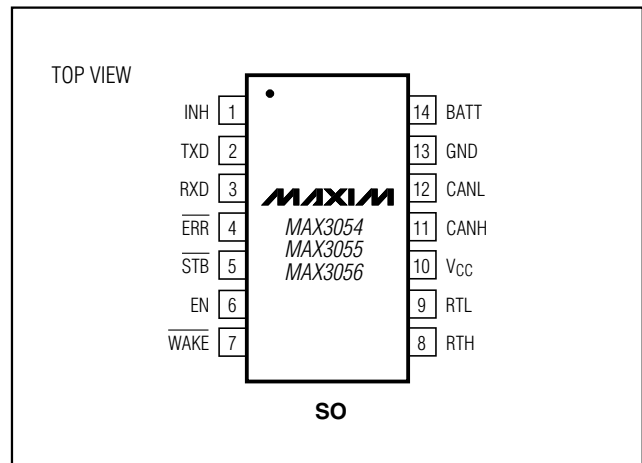

±80V Fault-Protected/Tolerant CAN Transceivers for In-Car Applications

ABSOLUTE MAXIMUM RATINGS

(All voltages are referenced to GND)

Supply Voltage (V_{CC})	-0.3V to +6V	INH Current	-0.5mA
Battery Voltage (V_{BATT})	-0.3V to +80V	Transient Voltage (ISO 7637)	-200V, +200V*
TXD, RXD, ERR, STB, EN	-0.3V to ($V_{CC} + 0.3V$)	Continuous Power Dissipation ($T_A = +70^\circ\text{C}$)	
CANH, CANL	-80V to +80V	14-Pin SO (derate 8.3mW/°C above +70°C)	667mW
RTH, RTL	-0.3V to +80V	Operating Temperature Range	-40°C to +125°C
RTH, RTL Current	±180mA	Junction Temperature	+150°C
WAKE	-0.3V to +80V	Storage Temperature Range	-65°C to +150°C
INH	-0.3V to ($V_{BATT} + 0.3V$)	Lead Temperature (soldering, 10s)	+300°C

*Pending completion of testing.

Stresses beyond those listed under "Absolute Maximum Ratings" may cause permanent damage to the device. These are stress ratings only, and functional operation of the device at these or any other conditions beyond those indicated in the operational sections of the specifications is not implied. Exposure to absolute maximum rating conditions for extended periods may affect device reliability.

DC ELECTRICAL CHARACTERISTICS

($V_{CC} = 5V \pm 5\%$, $V_{BATT} = +5V$ to +42V, $T_A = T_{MIN}$ to T_{MAX} , unless otherwise noted. Typical values are at $V_{CC} = 5V$, $V_{BATT} = 14V$, $R_1 = 100\Omega$ (Figure 2), $T_A = +25^\circ\text{C}$.) (Notes 1, 2)

PARAMETER	SYMBOL	CONDITIONS	MIN	TYP	MAX	UNITS
VOLTAGE SUPPLIES						
Supply Current	I_{CC}	Dominant normal operating mode, no load, TXD = 0		16	30	mA
		Recessive normal operating mode, TXD = V_{CC}		4	10	
		Low-power modes: $V_{TXD} = V_{CC}$, $V_{BATT} = 14V$		3	10	μA
Battery Current	I_{BATT}	Low-power modes at $V_{TRL} = V_{BATT}$, $V_{BATT} = V_{WAKE} = V_{INH} = 5V$ to 27V	5	54	125	μA
Battery Power on Flag Threshold	V_{PWRON}	Low-power modes	1.0		3.5	V
STB, EN, AND TXD						
High-Level Input Voltage	V_{IH}		2.4			V
Low-Level Input Voltage	V_{IL}				0.8	V
High-Level Input Current	I_{IH}	$V_{IN} = 4V$	$\overline{\text{STB}}$ and EN	9	20	μA
			TXD	-200	-80	
Low-Level Input Current	I_{IL}	$V_{IN} = 1V$	$\overline{\text{STB}}$ and EN	4	8	μA
			TXD	-800	-320	
Supply Voltage—Forced Standby Mode (Fail-Safe)	V_{FS}	$V_{BATT} = 14V$	2.75		4.50	V
RXD AND ERR						
High-Level Output Voltage	V_{OH}	$I_{OUT} = -1\text{mA}$	$V_{CC} - 0.5$		V_{CC}	V
Low-Level Output Voltage	V_{OL}	$I_{OUT} = 7.5\text{mA}$	0		0.9	V
WAKE						
Wake-Up Threshold Voltage	$V_{TH(WAKE)}$	$V_{STB} = 0V$	2.0	2.7	3.4	V
Low-Level Input Current	$I_{IL(WAKE)}$	$V_{WAKE} = 0V$	-10	-4	-1	μA

±80V Fault-Protected/Tolerant CAN Transceivers for In-Car Applications

MAX3054/MAX3055/MAX3056

DC ELECTRICAL CHARACTERISTICS (continued)

($V_{CC} = 5V \pm 5\%$, $V_{BATT} = +5V$ to $+42V$, $T_A = T_{MIN}$ to T_{MAX} , unless otherwise noted. Typical values are at $V_{CC} = 5V$, $V_{BATT} = 14V$, $R1 = 100\Omega$ (Figure 2), $T_A = +25^\circ C$.) (Notes 1, 2)

PARAMETER	SYMBOL	CONDITIONS	MIN	TYP	MAX	UNITS
INH						
High-Level Voltage Drop	ΔV_H	$I_{INH} = -0.18mA$, standby mode			0.8	V
Leakage Current	$I_{LEAK(INH)}$	Sleep mode, $V_{INH} = 0V$			5	μA
CANH, CANL						
Differential Receiver Threshold	V_{DIFF}	$V_{CC} = 5V$, no failures and bus failures 1, 2, 5, 9	-3.5	-3.2	-2.9	V
		$V_{CC} = 4.75V$ to $5.25V$, no failures and bus failures 1, 2, 5, 9	$-0.70 \times V_{CC}$	$-0.58 \times V_{CC}$		
Differential Receiver Hysteresis	HYST	No failures and bus failures 1, 2, 5, 9		18		mV
CANH Recessive Output Voltage	V_{OCH}	$TXD = V_{CC}$, $RTH < 4k\Omega$			200	mV
CANL Recessive Output Voltage	V_{OCL}	$TXD = V_{CC}$, $RTH < 4k\Omega$	$V_{CC} - 0.2$			V
CANH Dominant Output Voltage	V_{OCHDOM}	$TXD = 0V$, $R1 = 100\Omega$	$V_{CC} - 1.4$			V
CANL Dominant Output Voltage	V_{OCLDOM}	$TXD = 0V$, $R1 = 100\Omega$			1.4	V
CANH Output Current	$I_O(CANH)$	$V_{CANH} = 0V$, $TXD = 0V$	-150	-86		mA
		Low-power modes, $V_{CANH} = 0V$, $V_{CC} = 5V$	-10			μA
CANL Output Current	$I_O(CANL)$	$V_{CANL} = 14V$, $TXD = 0V$		75	130	mA
		Low-power modes, $V_{CANL} = 42V$, $V_{BATT} = 42V$, $RTL = open$			20	μA
Voltage Detection Threshold for Short Circuit to Battery on CANH	$V_{DET(CANH)}$	$V_{CC} = 4.75V$ to $5.25V$	$0.30 \times V_{CC}$	$0.37 \times V_{CC}$		V
		Low-power modes	1.1		2.5	
Voltage Detection Threshold for Short Circuit to GND on CANL	$V_{DTG(CANL)}$	Low-power modes	2.5		3.9	V
Voltage Detection Threshold for Short Circuit to Battery on CANL	$V_{DET(CANL)}$	Normal mode, $V_{CC} = 5V$	6.4	7.3	8.2	V
CANL Wake-Up Threshold	$V_{THL(WAKE)}$	Low-power modes	2.5	3.2	3.9	V
CANH Wake-Up Threshold	$V_{THH(WAKE)}$	Low-power modes	1.1	1.8	2.5	V
CANH Single-Ended Receiver Threshold (Failures 4, 6, 7)	$V_{SE(CANH)}$	$V_{CC} = 5V$	1.50	1.70	1.85	V
		$V_{CC} = 4.75V$ to $5.25V$	$0.30 \times V_{CC}$	$0.37 \times V_{CC}$		
CANH Single-Ended Receiver Hysteresis	HYST			10		mV

±80V Fault-Protected/Tolerant CAN Transceivers for In-Car Applications

DC ELECTRICAL CHARACTERISTICS (continued)

($V_{CC} = 5V \pm 5\%$, $V_{BATT} = +5V$ to $+42V$, $T_A = T_{MIN}$ to T_{MAX} , unless otherwise noted. Typical values are at $V_{CC} = 5V$, $V_{BATT} = 14V$, $R1 = 100\Omega$ (Figure 2), $T_A = +25^\circ C$.) (Notes 1, 2)

PARAMETER	SYMBOL	CONDITIONS	MIN	TYP	MAX	UNITS
CANL Single-Ended Receiver Threshold	$V_{SE(CANL)}$	$V_{CC} = 5V$	3.15	3.30	3.45	V
		$V_{CC} = 4.75V$ to $5.25V$	$0.63 \times V_{CC}$	$0.69 \times V_{CC}$		
CANL Single-Ended Receiver Hysteresis	HYST	Failures 3, 8		10		mV
RTL AND RTH						
RTL to V_{CC} Switch On-Resistance	$R_{SW(RTL)}$	$I_O = -10mA$		36	100	Ω
RTH to V_{CC} Switch On-Resistance	$R_{SW(RTH)}$	$I_O = 10mA$		23	100	Ω
Output Current on Pin RTL	$I_{O(RTL)}$	Low-power modes, $V_{RTL} = 0$	-1.25	-0.65	-0.30	mA
RTL Pullup Current	$ I_{PU(RTL)} $	Normal and failures 4, 6, 7, $RTL = 0V$	20	107	200	μA
RTH Pulldown	$ I_{PU(RTH)} $	Normal and failures 3, 8, $RTL = V_{CC}$	20	106	200	μA
THERMAL SHUTDOWN						
Shutdown Junction Temperature	T_J	For shutdown		165		$^\circ C$
	T_{JF6}	During failure 6—switch off CANL only		140		
Thermal Protection Hysteresis	T_{HYS}			15		$^\circ C$

AC ELECTRICAL CHARACTERISTICS

($V_{CC} = 5V \pm 5\%$, $V_{BATT} = +5V$ to $+42V$, $T_A = T_{MIN}$ to T_{MAX} , unless otherwise noted. Typical values are at $V_{CC} = 5V$, $V_{BATT} = 14V$, $R1 = 100\Omega$ (Figure 2), $T_A = +25^\circ C$.) (Notes 1, 2)

PARAMETER	SYMBOL	CONDITIONS	MIN	TYP	MAX	UNITS
TRANSITION TIME						
CANL and CANH Bus Output Transition Time Recessive to Dominant (10% to 90%)	$t_{(r-d)}$	$C_L = 330pF$, MAX3054 (250kbps)		38		ns
		$C_L = 220pF$ to $3.3nF$, MAX3055 (125kbps)	100		700	
		$C_L = 560pF$ to $10nF$, MAX3056 (40kbps)	0.7		3.3	μs
CANL and CANH Bus Output Transition Time Dominant to Recessive (10% to 90%)	$t_{(d-r)}$	$C_L = 330pF$, MAX3054 (250kbps)		130		ns
		$C_L = 220pF$ to $1nF$, MAX3055 (125kbps)	200		1200	
		$C_L = 560pF$ to $3.3nF$, MAX3056 (40kbps)	0.5		2.8	μs
PROPAGATION DELAY TXD TO RXD LOW—DOMINANT TRANSMISSION (Figures 1, 2)						
Differential Reception	t_{PDLD}	No failures, $C_L = 330pF$, MAX3054 (250kbps)			600	ns
		Bus failures 1, 2, 5, 9, $C_L = 330pF$, MAX3054 (250kbps)			750	
		No failures and bus failures 1, 2, 5, 9, $C_L = 1nF$, MAX3055 (125kbps)			1.5	μs
		No failures and bus failures 1, 2, 5, 9, $C_L = 3.3nF$, MAX3056 (40kbps)			4.7	

±80V Fault-Protected/Tolerant CAN Transceivers for In-Car Applications

MAX3054/MAX3055/MAX3056

AC ELECTRICAL CHARACTERISTICS (continued)

(V_{CC} = 5V ±5%, V_{BATT} = +5V to +42V, T_A = T_{MIN} to T_{MAX}, unless otherwise noted. Typical values are at V_{CC} = 5V, V_{BATT} = 14V, R1 = 100Ω (Figure 2), T_A = +25°C.) (Notes 1, 2)

PARAMETER	SYMBOL	CONDITIONS		MIN	TYP	MAX	UNITS
Single-Ended Reception	t _{PD} SE	Bus failures 3, 4, 6, 7, 8, C _L = 330pF, MAX3054 (250kbps)				750	ns
		Bus failures 3, 4, 6, 7, 8, C _L = 1nF, MAX3055 (125kbps)				1.5	μs
		Bus failures 3, 4, 6, 7, 8, C _L = 3.3nF, MAX3056 (40kbps)				4.7	
PROPAGATION DELAY TXD TO RXD HIGH—RECESSIVE TRANSMISSION (Figures 1, 2)							
Differential Reception	t _{PD} H _D	No failures and bus failures 1, 2, 5, 9, C _L = 330pF, MAX3054 (250kbps)				950	ns
		No failures and bus failures 1, 2, 5, 9, C _L = 1nF, MAX3055 (125kbps)				1.9	μs
		No failures and bus failures 1, 2, 5, 9, C _L = 3.3nF, MAX3056 (40kbps)				5.95	
Single-Ended Reception	t _{PD} H _{SE}	Bus failures 3, 4, 6, 7, 8, C _L = 330pF, MAX3054 (250kbps)				950	ns
		Bus failures 3, 4, 6, 7, 8, C _L = 1nF, MAX3055 (125kbps)				1.9	μs
		Bus failures 3, 4, 6, 7, 8, C _L = 3.3nF, MAX3056 (40kbps)				5.95	
WAKE-UP TIMING							
Minimum Time for Wake-Up on CANL and CANH or WAKE	t _{WAKE}			8		38	μs
FAILURES TIMING							
Failures 3 and 8 Detection Time	t _{DET}	Normal and low-power mode	MAX3054 (250kbps), MAX3055 (125kbps)	1.9	5.7	9.5	ms
			MAX3056 (40kbps)	5.5	16.5	27.0	
Failures 4 and 7 Detection Time		Normal and low-power mode	MAX3054 (250kbps), MAX3055 (125kbps)	0.3	1	1.9	
			MAX3056 (40kbps)	1.0	3.2	5.5	
Failure 6 Detection Time		Normal mode	MAX3054 (250kbps), MAX3055 (125kbps)	0.35	1.1	1.85	
			MAX3056 (40kbps)	0.93	2.97	5.00	

±80V Fault-Protected/Tolerant CAN Transceivers for In-Car Applications

AC ELECTRICAL CHARACTERISTICS (continued)

($V_{CC} = 5V \pm 5\%$, $V_{BATT} = +5V$ to $+42V$, $T_A = T_{MIN}$ to T_{MAX} , unless otherwise noted. Typical values are at $V_{CC} = 5V$, $V_{BATT} = 14V$, $R1 = 100\Omega$ (Figure 2), $T_A = +25^\circ C$.) (Notes 1, 2)

PARAMETER	SYMBOL	CONDITIONS		MIN	TYP	MAX	UNITS
Failures 3 and 8 Recovery Time		Normal and low-power mode	MAX3054 (250kbps), MAX3055 (125kbps)	0.36	1.14	1.90	ms
			MAX3056 (40kbps)	1.0	3.2	5.5	
Failures 4 and 7 Recovery Time	t _{REC}	Normal mode	MAX3054 (250kbps)	1.7	5.6	9.5	μs
			MAX3055 (125kbps)	7	23	38	
			MAX3056 (40kbps)	22	70	119	
Failure 6 Recovery Time		Normal mode	MAX3054 (250kbps), MAX3055 (125kbps)	0.35	1.1	1.85	ms
			MAX3056 (40kbps)	1.0	3.2	5.5	
Minimum Hold Time of Go-to-Sleep Command	t _{HMIN}			5		50	μs
Disable Time of TXD Permanent Dominant Timer	t _{DIS(TXD)}	V _{TXD} = 0	MAX3054 (250kbps), MAX3055 (125kbps)	0.9		4.5	ms
			MAX3056 (40kbps)	2.34		12.50	
Pulse Count Difference for Failures 1, 2, 5, 9 Detection (\overline{ERR} Becomes Low)	Count			4			
Pulse Count Difference for Failures 1, 2, 5, 9 Recovery (\overline{ERR} Becomes High)				3	4	5	

Note 1: All currents into the device are positive; all currents out of the device are negative. All voltages are referenced to device ground, unless otherwise noted.

Note 2: Failure modes 1 through 9 are explained in Table 1 and in the *Detailed Description* section.

±80V Fault-Protected/Tolerant CAN Transceivers for In-Car Applications

Timing Diagram/Test Circuits

MAX3054/MAX3055/MAX3056

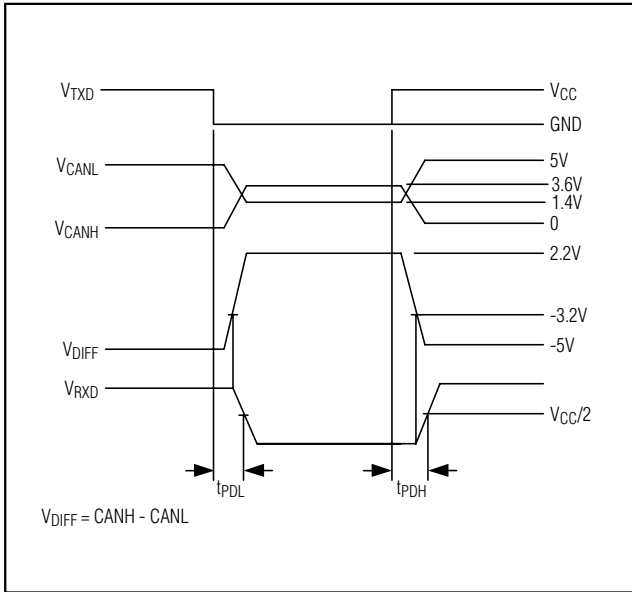

Figure 1. Timing Diagram for Dynamic Characteristics

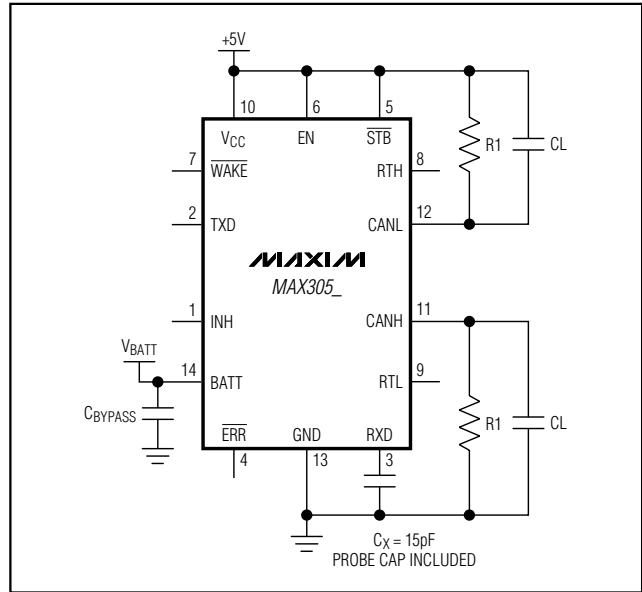

Figure 2. Test Circuit for Dynamic Characteristics

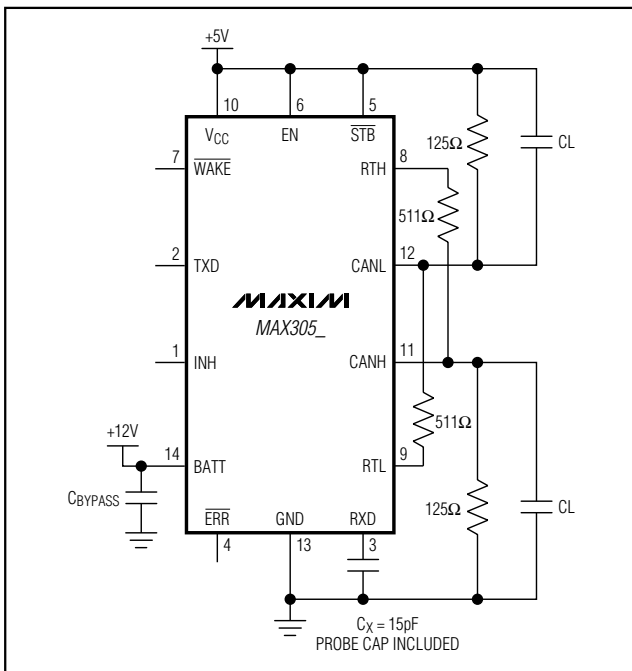

Figure 3. Test Circuit for Typical Operating Characteristics

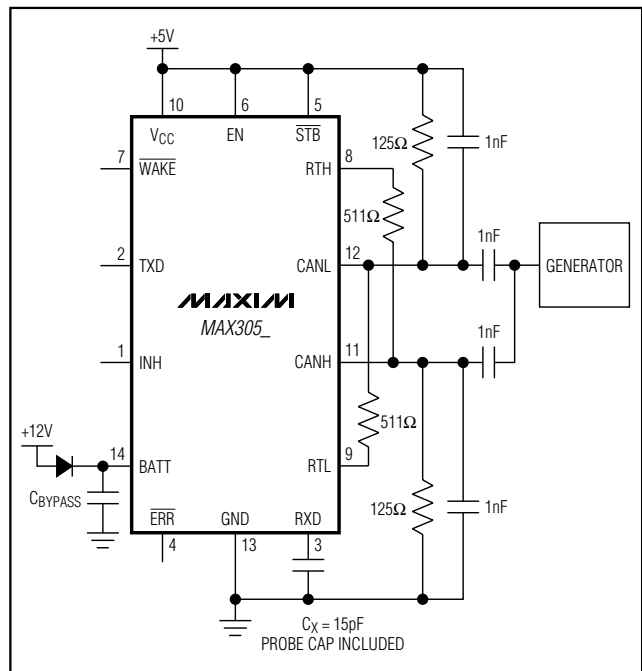
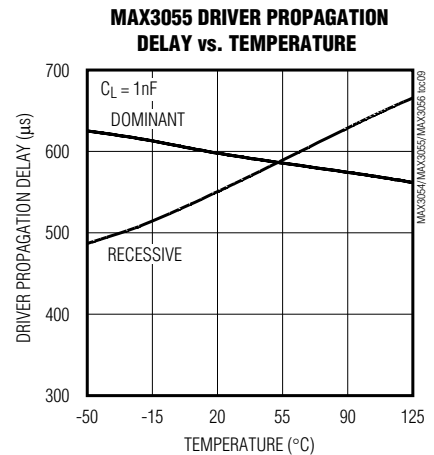
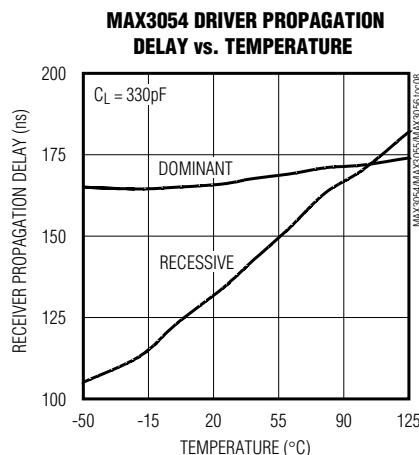
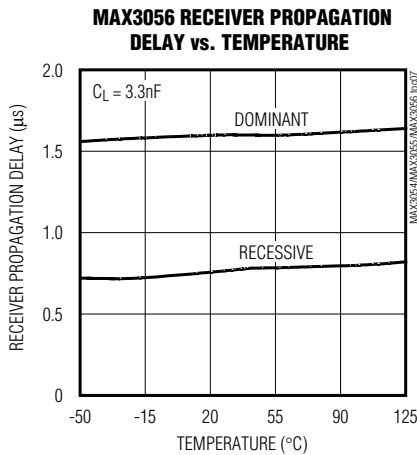
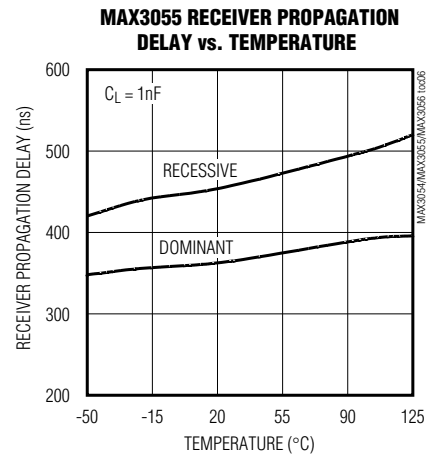
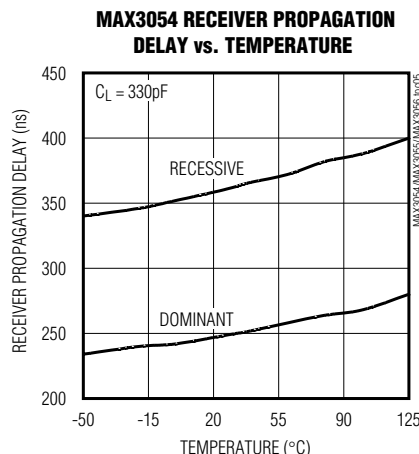
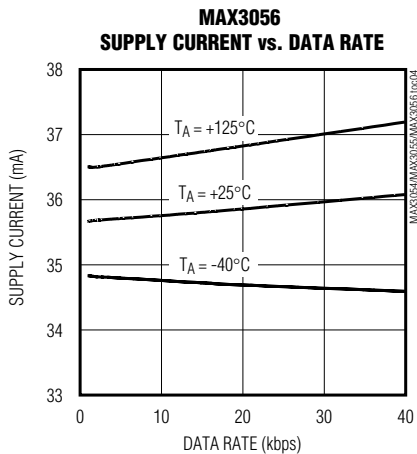
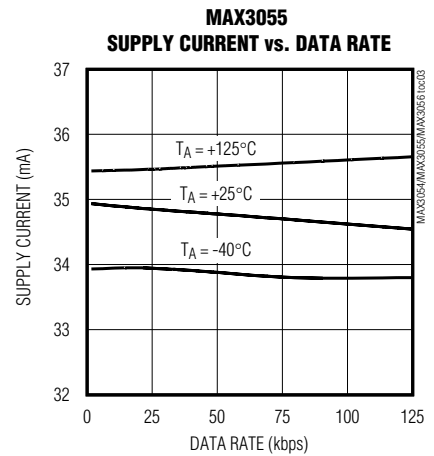
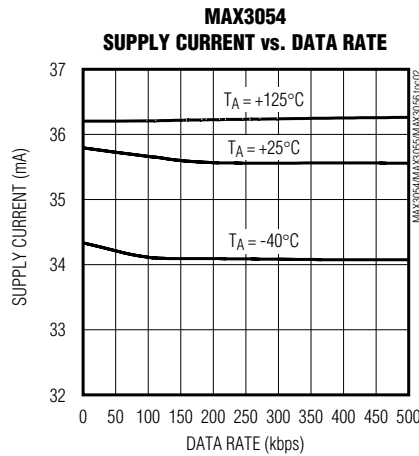
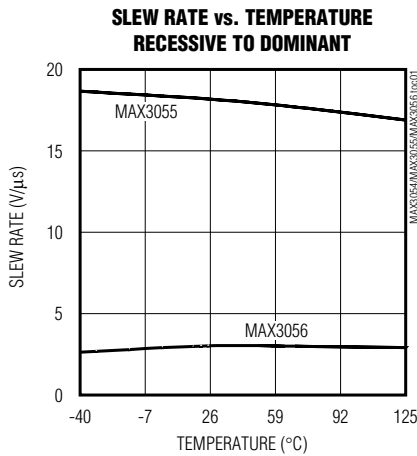

Figure 4. Test Circuit for Automotive Transients

±80V Fault-Protected/Tolerant CAN Transceivers for In-Car Applications

Typical Operating Characteristics

($V_{CC} = 5V$, $V_{BATT} = +12V$, $R_{TL} = R_{TH} = 511\Omega$, $R_1 = 125\Omega$, and $T_A = +25^\circ C$; see Figure 3.)



±80V Fault-Protected/Tolerant CAN Transceivers for In-Car Applications

Typical Operating Characteristics (continued)

($V_{CC} = 5V$, $V_{BATT} = +12V$, $R_{TL} = R_{TH} = 511\Omega$, $R_1 = 125\Omega$, and $T_A = +25^\circ C$; see Figure 3.)

MAX3054/MAX3055/MAX3056

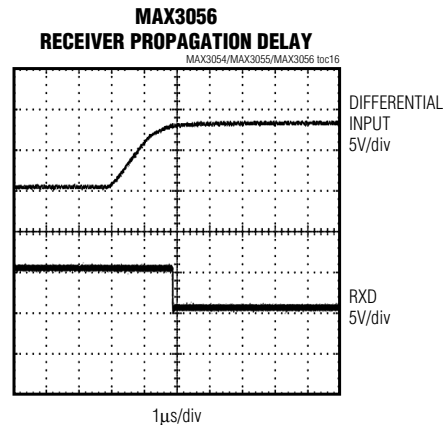
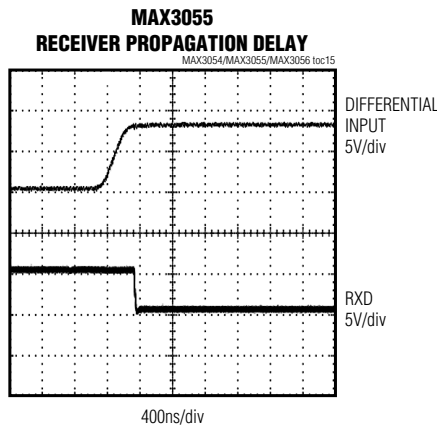
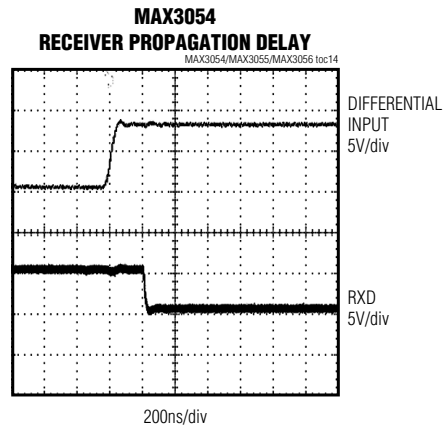
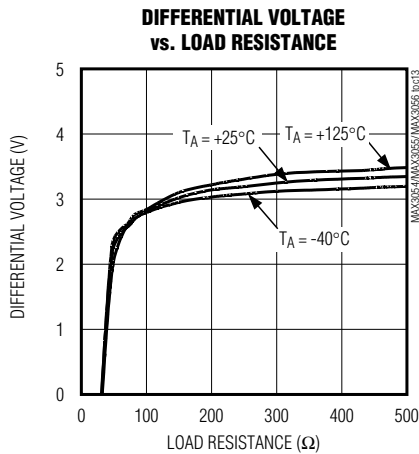
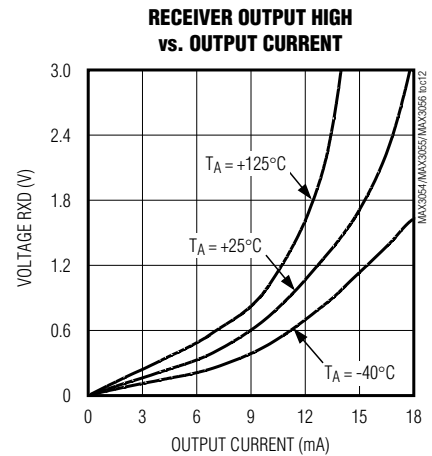
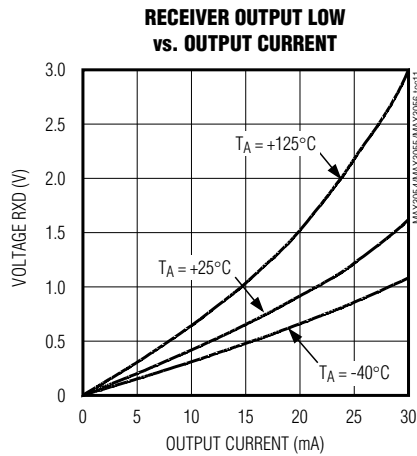
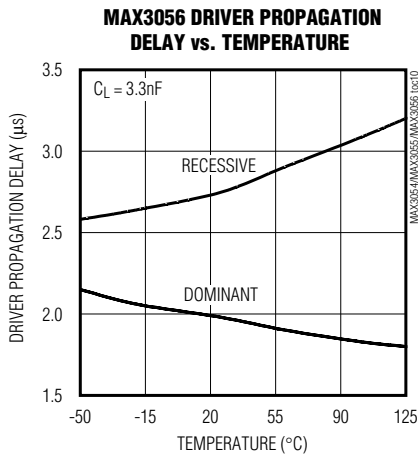

$\pm 80V$ Fault-Protected/Tolerant CAN Transceivers for In-Car Applications

Typical Operating Characteristics (continued)

($V_{CC} = 5V$, $V_{BATT} = +12V$, $R_{TL} = R_{TH} = 511\Omega$, $R_1 = 125\Omega$, and $T_A = +25^\circ C$; see Figure 3.)

**DRIVER PROPAGATION DELAY
RECESSIVE TO DOMINANT**

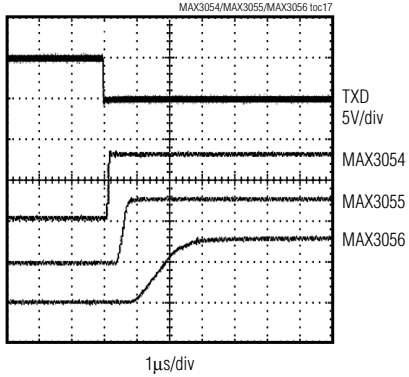

**DRIVER PROPAGATION DELAY
DOMINANT TO RECESSIVE**

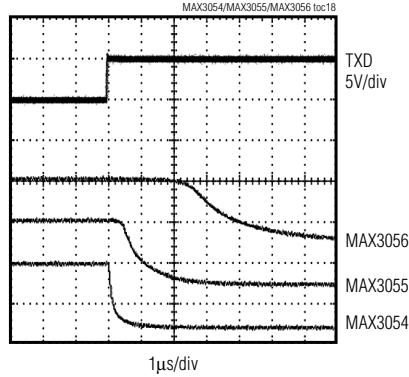

**TXD-TO-RXD PROPAGATION DELAY
DOMINANT TO RECESSIVE**

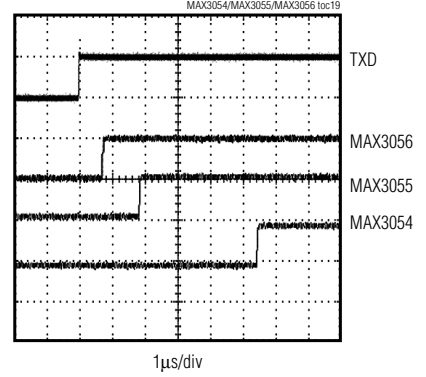

**TXD-TO-RXD PROPAGATION DELAY
RECESSIVE TO DOMINANT**

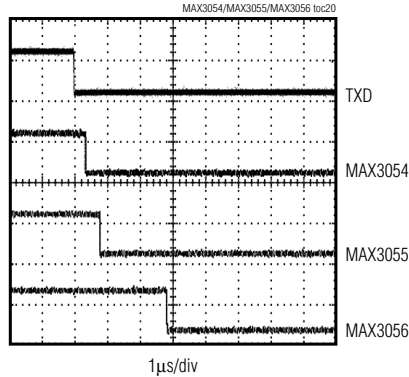

MAX3056 CAN BUS AT 40kbps

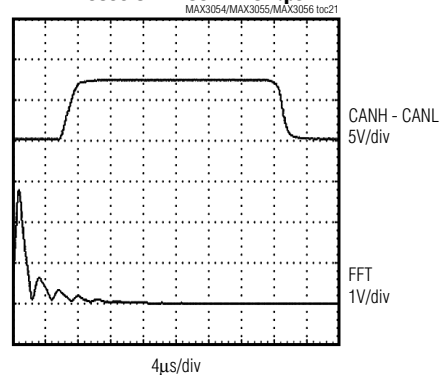

MAX3055 CAN BUS AT 125kbps

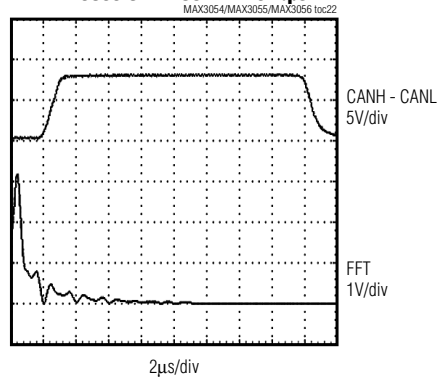

MAX3054 CAN BUS AT 250kbps

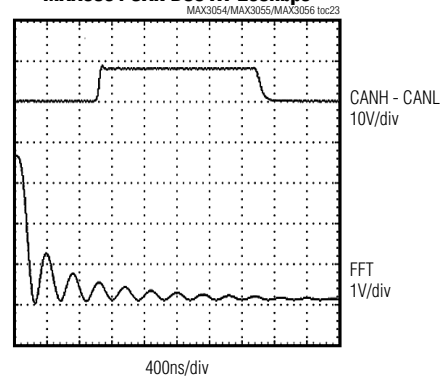

±80V Fault-Protected/Tolerant CAN Transceivers for In-Car Applications

Pin Description

PIN	NAME	FUNCTION
1	INH	Inhibit Output. Inhibit output is for switching an external voltage regulator if a wake-up signal occurs.
2	TXD	Transmit Data Input
3	RXD	Receive Data Output
4	$\overline{\text{ERR}}$	Error. Wake-up and power-on indication output; active low in normal operating mode when the bus has a failure and in low-power modes (wake-up signal or power-on standby).
5	$\overline{\text{STB}}$	Standby. The digital control signal input (active low) defines, together with input signal on pin EN, the state of the transceiver (in normal and low-power modes).
6	EN	Enable. The digital control signal input defines, together with input signal on pin $\overline{\text{STB}}$, the state of the transceiver (in normal and low-power modes).
7	$\overline{\text{WAKE}}$	Wake-Up. Local wake-up signal input; falling and rising edges are both detected.
8	RTH	Termination Resistor. Termination resistor connection for CANH bus.
9	RTL	Termination Resistor. Termination resistor connection for CANL bus.
10	V _{CC}	Supply Voltage. Bypass to ground with a 0.1μF capacitor.
11	CANH	High-Level Voltage Bus Line
12	CANL	Low-Level Voltage Bus Line
13	GND	Ground
14	BATT	Battery Supply. Bypass to ground with a 0.1μF capacitor.

Detailed Description

The MAX3054/MAX3055/MAX3056 interface between the protocol controller and the physical wires of the bus lines in a CAN. The devices provide differential transmit capability and switch to single-wire mode if certain fault conditions occur (see the *Failure Management* section). The MAX3054/MAX3055/MAX3056 guarantee full wake-up capability during failure modes.

The extended fault-protection range of CANH and CANL bus lines (±80V) allows for use in 42V automotive applications. A current-limiting circuit protects the transmitter output stage against overcurrent faults. This feature prevents destruction of the transmitter output stage. If the junction temperature exceeds a value of approximately +165°C, the transmitter output stages are disabled. The CANH and CANL lines are also protected against electrical transients, which can occur in an automotive environment.

The transceiver provides three low-power modes that can be entered and exited through pins STB and EN. An output INH pin can be used for deactivation of an external voltage regulator.

The MAX3054/MAX3055/MAX3056 are designed to provide optimal operation for a specified data rate. The

MAX3054 is ideal for high data rates of 250kbps. The MAX3055 is used for data rates of 125kbps, and the MAX3056 is designed for 40kbps applications. For the 40kbps and 125kbps versions, the built-in slope-control feature allows the use of unshielded cables and receiver input filters guarantee high noise immunity.

Normal Operation Mode

Transmitter

The transmitter converts a single-ended input (TXD) from the CAN controller to differential outputs for the bus lines (CANH, CANL).

Receiver

The receiver takes differential input from the bus lines (CANH, CANL) and converts this data as a single-ended output (RXD) to the CAN controller. It consists of a comparator that senses the difference $\Delta V = (\text{CANH} - \text{CANL})$ with respect to an internal threshold.

BATT

The main function of BATT is to supply power to the device when vehicle battery voltage is supplied.

BATT can handle up to +80V making it ideal for 42V automotive systems allowing power-up of the device when the ignition is turned on.

±80V Fault-Protected/Tolerant CAN Transceivers for In-Car Applications

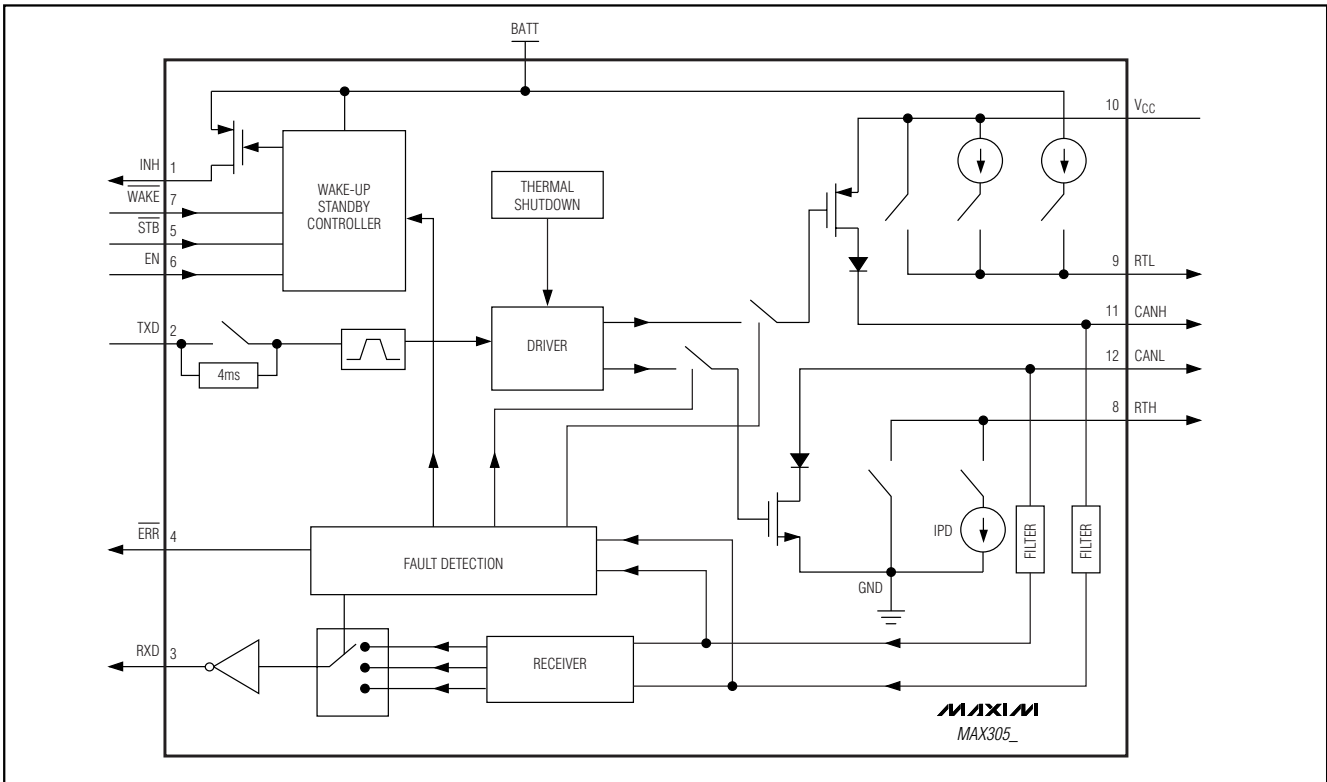

Figure 5. Block Diagram

INH

Inhibit is an output that allows for the control of an external voltage regulator. On a wake-up request or power-up on BATT, the transceiver sets the output INH high. This feature enables the external voltage regulator to be shut down during sleep mode to reduce power consumption.

INH is floating while entering the sleep mode and stays floating during the sleep mode. If INH is left floating, it is not set to a high level again until the following events occur:

- Power-on (VBATT switching on at cold start)
- Rising or falling edge on WAKE
- Dominant signal longer than 38µs during EN or STB at low level

The signals on STB and EN are internally set to a low level when VCC is below a certain threshold voltage providing fail-safe functionality.

After power-on (VBATT switched on) the signal on INH becomes HIGH and an internal power-on flag is set. This flag can be read in the power-on standby mode through ERR (STB = 1, EN = 0) and is reset by entering the normal operating mode.

ERR

ERR is a wake-up and power-on indicator, as well as an error detector. Upon power-up, wake-up, or when a bus failure is detected, the output signal on ERR becomes LOW. Upon error recovery, the output signal on ERR is set HIGH.

STB

STB is the standby digital control signal into the logic controller. This is an active-low input that is used with EN to define the status of the transceiver in normal and low-power modes.

EN

EN is the enable digital control signal into the logic controller used in conjunction with STB to define the status of the transceiver in normal and low-power modes.

WAKE

WAKE is an input to the logic controller within the device to signal a wake-up condition. If WAKE receives a positive or negative pulse for a period longer than tWAKE, wake-up occurs.

±80V Fault-Protected/Tolerant CAN Transceivers for In-Car Applications

MAX3054/MAX3055/MAX3056

Driver Output Protection

Thermal Shutdown

If the junction temperature exceeds +165°C, the driver is switched off. Thermal hysteresis is 15°C, disabling thermal shutdown once the temperature reaches +150°C.

Overcurrent Protection

A current-limiting circuit protects the transmitter output stage against a short circuit to a positive and negative battery voltage. Although the power dissipation increases during this fault condition, this feature prevents destruction of the transmitter output stage.

Failure Management

The failure detector is fully active in normal operating mode. After the detection of a single failure, the detector switches to the appropriate state (see Table 1).

The differential receiver threshold voltage is set to -3.2V typically ($V_{CC} = 5V$). This ensures correct reception with a noise margin as high as possible in the normal operating mode and in the event of failures 1, 2, 5, and 9.

If any of the wiring failures occur, the output signal on pin \overline{ERR} becomes LOW after detection. On error recovery, the output signal on pin \overline{ERR} becomes HIGH.

Table 1. Failure States

FAILURE	DESCRIPTION	MODE
1	CANH wire interrupted	Normal
2	CANL wire interrupted	Normal
3	CANH short circuited to battery	All
4	CANL short circuited to ground	All
5	CANH short circuited to ground	Normal
6	CANL short circuited to battery	Normal
7	CANL mutually short circuited to CANH	All
8	CANH short circuited to V_{CC}	All
9	CANL short circuited to V_{CC}	Normal

Failure 1—CANH Wire Interrupted (Normal Mode Only)

MODE	DESCRIPTION
Detection	The external termination resistance connected to the RTH pin provides an instantaneous pulldown of the open CANH line to GND. Detection is provided, sensing the pulse-count difference between CANH and CANL (pulse count = 4).
Receiver	The receiver remains in differential mode. No received data lost.
Driver	Driver remains in differential mode. No transmission data lost.
Recovery	Recovery is provided sensing the pulse-count difference between CANH and CANL after the detection of four consecutive pulses.

Failure 2—CANL Wire Interrupted (Normal Mode Only)

MODE	DESCRIPTION
Detection	The external termination resistance connected to the RTL pin provides an instantaneous pullup of the CANL line to V_{CC} . Detection is provided, sensing the pulse-count difference between CANL and CANH (pulse count = 4).
Receiver	The receiver remains in differential mode. No received data lost.
Driver	Driver remains in differential mode. No transmission data lost.
Recovery	Recovery is provided, sensing the pulse-count difference between CANL and CANH after the detection of four consecutive pulses.

$\pm 80V$ Fault-Protected/Tolerant CAN Transceivers for In-Car Applications

Table 1. Failure States (continued)

Failure 3—CANH Short Circuited to Battery

MODE	DESCRIPTION
Detection	Sensing a permanent dominant condition on CANH for a timeout period.
Receiver	Receiver switches to single ended on CANL.
Driver	CANH and RTH are both switched off (high impedance) and transmission continues on CANL after timeout.
Recovery	When the short is removed, the recessive bus voltage is restored. If the differential voltage remains below the recessive threshold level for the timeout period, reception and transmission switch back to the differential mode.

Failure 4—CANL Short Circuited to GND

MODE	DESCRIPTION
Detection	Sensing a permanent dominant condition for a timeout period.
Receiver	Receiver switches to single ended on CANH.
Driver	CANL and RTL are both switched off (high impedance) and transmission continues on CANH after timeout.
Recovery	When the short is removed, the recessive bus voltage is restored. If the differential voltage remains below the recessive threshold level for the timeout period, reception and transmission switch back to the differential mode.

Failure 5—CANH Short Circuited to Ground or Below Ground (Normal Mode Only)

MODE	DESCRIPTION
Detection	Detection is provided, sensing the pulse-count difference between CANH and CANL (pulse count = 4).
Receiver	Receiver remains in differential mode. No received data lost.
Driver	RTH remains on and CANH remains enabled.
Recovery	Recovery is provided, sensing the edge-count difference between CANH and CANL after the detection of four consecutive pulses.

Failure 6—CANL Short Circuited to Battery (Normal Mode Only)

MODE	DESCRIPTION
Detection	Detected by a comparator for CANL > 7.3V after a timeout period.
Receiver	Receiver switches to single ended on CANH after timeout.
Driver	RTL is switched off after timeout. CANH remains active.
Recovery	Sensing CANL < 7.3V after the timeout period.

Failure 7—CANL Mutually Short Circuited to CANH

MODE	DESCRIPTION
Detection	Sensing a permanent dominant condition on the differential comparator (CANH - CANL > -3.2V) for the timeout period.
Receiver	Receiver switches to CANH single-ended mode after timeout.
Driver	CANL and RTL are both switched off after timeout. Transmission remains ongoing on CANH.
Recovery	When the short is removed, the recessive bus voltage is restored (RTL on if CANH - CANL < -3.2V) but CANL still remains disabled and ERR = 0. If the differential voltage remains below the recessive threshold level (CANH - CANL < -3.2V) for the timeout period, reception and transmission switch back to the differential mode.

±80V Fault-Protected/Tolerant CAN Transceivers for In-Car Applications

MAX3054/MAX3055/MAX3056

Table 1. Failure States (continued)
Failure 8—CANH Short Circuited to V_{CC}

MODE	DESCRIPTION
Detection	Sensing a permanent dominant condition on CANH for a timeout period.
Receiver	Receiver switches to single ended on CANL.
Driver	CANH and RTH are both switched off (high impedance) and transmission continues on CANL after timeout.
Recovery	When the short is removed, the recessive bus voltage is restored. If the differential voltage remains below the recessive threshold level for the timeout period, reception and transmission switch back to the differential mode.

Failure 9—CANL Short Circuited to V_{CC} (Normal Mode Only)

MODE	DESCRIPTION
Detection	Detection is provided, sensing the pulse-count difference between CANL and CANH (pulse count = 4).
Receiver	Receiver remains in differential mode. No received data lost.
Driver	Driver remains in differential mode. No transmission data lost.
Recovery	Recovery is provided, sensing the pulse-count difference between CANL and CANH after the detection of four consecutive pulses.

Table 2. Summary of the Driver Outputs and Internal Switches State During Fault Conditions

FAILURE NO.	DESCRIPTION	MODE	INTERNAL SWITCHES STATE	DRIVER OUTPUTS STATE	
				CANH	CANL
No failure	—	Normal	RTH, RTL on	Enabled	Enabled
No failure	—	Low power	RTH, I _{RTL} on	Disabled	Disabled
1	CANH wire interrupted	Normal	RTH, RTL on	Enabled	Enabled
2	CANL wire interrupted	Normal	RTH, RTL on	Enabled	Enabled
3	CANH short to BATT	All	RTH off	Disabled	Enabled
4	CANL short to GND	All	RTL or I _{RTL} off	Enabled	Disabled
5	CANH short to GND	Normal	RTH, RTL on	Enabled	Enabled
6	CANL short to BATT	Normal	RTL off, RTH on	Enabled	Enabled
7	CANL short to CANH	All	RTL or I _{RTL} off	Enabled	Disabled
8	CANH short to V _{CC}	All	RTH off	Disabled	Enabled
9	CANL short to V _{CC}	Normal	RTH, RTL on	Enabled	Enabled

Note: The RTH-pulldown current switch and the RTL-pullup current switch are closed in normal mode with or without fault conditions, open in sleep mode.

$\pm 80V$ Fault-Protected/Tolerant CAN Transceivers for In-Car Applications

Low-Power Modes

The transceiver provides three low-power modes that can be entered or exited through pins \overline{STB} and EN (Table 3).

Sleep Mode

The sleep mode is the mode with the lowest power consumption. INH is switched to high impedance for deactivation of the external voltage regulator. CANL is biased to the battery voltage through RTL. If the supply voltage is provided, RXD and ERR signal the wake-up interrupt.

Standby Mode

The standby mode reacts the same as the sleep mode, but with a HIGH level on INH. Standby mode can be used when the external voltage regulator needs to be kept active during low-power operation.

Power-On Standby Mode

The power-on standby mode behaves similarly to the standby mode with the battery power-on flag of the wake-up interrupt signal on ERR. This mode is only for reading the power-on flag. INH can be high or low in the power-on standby mode. When the device goes from standby mode to power-on standby mode, INH is HIGH. When the device goes from sleep mode to power-on standby mode, INH is low.

Wake-Up

Wake-up requests are recognized by the transceiver when a dominant signal is detected on either bus line or if WAKE detects a pulse for more than 38 μ s. On a wake-up request, INH is set high to activate an external voltage regulator.

If V_{CC} is provided, the wake-up request can be read on the ERR or RXD outputs.

To prevent false wake-up due to transients or RF fields, the wake-up voltage levels have to be maintained for more than 38 μ s. In the low-power modes, the failure detection circuit remains partly active to prevent increased power consumption in the event of failures 3, 4, 7, and 8.

Applications Information

The MAX3054/MAX3055/MAX3056 are capable of sustaining a network of up to 32 transceivers on a single bus. The fault-tolerant transceivers are designed to operate at a total termination resistance of 100 Ω . Both CANH and CANL lines are terminated with 100 Ω . Since the total termination resistance of the system is distributed over the entire bus, each of the transceivers contributes only part of the total 100 Ω termination. The values of the termination resistors RTL and RTH vary according to the size of the system and need to be calculated. It is not required that each transceiver be terminated with the same value, the total termination need only be a total 100 Ω .

The minimum termination resistor value allowed for each transceiver is 500 Ω , due to the driving capability of RTH and RTL. This makes it impossible to achieve a total termination resistance of 100 Ω for systems smaller than five transceivers. Typically this does not create a problem because smaller systems usually have shorter bus cables and have no problem with higher total termination resistance.

To reduce EMI in the case of an interrupted bus wire it is recommended not to exceed 6k Ω termination resistance at a single transceiver even though a higher value is specified.

Table 3. Low-Power Modes

MODE	\overline{STB}	EN	ERR		RXD		RTL SWITCHED TO
			LOW	HIGH	LOW	HIGH	
Go-to-Sleep Command	0	1	Wake-up interrupt signal (Notes 2 and 3)	—	Wake-up interrupt signal (Notes 2 and 3)	—	V_{BATT}
Sleep	0	0 (Note 1)					
Standby	0	0					
Power-On Standby	1	0	V_{BATT} power-on flag	—	Wake-up interrupt signal (Notes 2 and 3)	—	V_{BATT}
Normal Operating	1	1	Error flag	No error flag	Dominant received data	Recessive received data	V_{CC}

Note 1: In case the go-to-sleep command was used before.

Note 2: If the supply voltage V_{CC} is present.

Note 3: Wake-up interrupts are released when entering the normal operating mode.

$\pm 80V$ Fault-Protected/Tolerant CAN Transceivers for In-Car Applications

Reduced EMI and Reflections

Due to internal slope control for the MAX3055/MAX3056, the CANH and CANL outputs are slew-rate limited. This minimizes EMI and reduces reflections caused by improperly terminated cables. In general, a transmitter's rise time relates directly to the length of an unterminated stub, which can be driven with only minor waveform reflections. The following equation expresses this relationship conservatively:

$$\text{Length} = t_{\text{RISE}} / (15\text{ns/ft})$$

where t_{RISE} is the transmitter's rise time.

The MAX3054/MAX3055/MAX3056 require no special layout considerations beyond common practices. Bypass V_{CC} to GND with a $0.1\mu\text{F}$ ceramic capacitor mounted close to the IC with short lead lengths and wide trace widths.

Chip Information

TRANSISTOR COUNT: 1300

PROCESS: BiCMOS

MAX3054/MAX3055/MAX3056

±80V Fault-Protected/Tolerant CAN Transceivers for In-Car Applications

Package Information

(The package drawing(s) in this data sheet may not reflect the most current specifications. For the latest package outline information, go to www.maxim-ic.com/packages.)

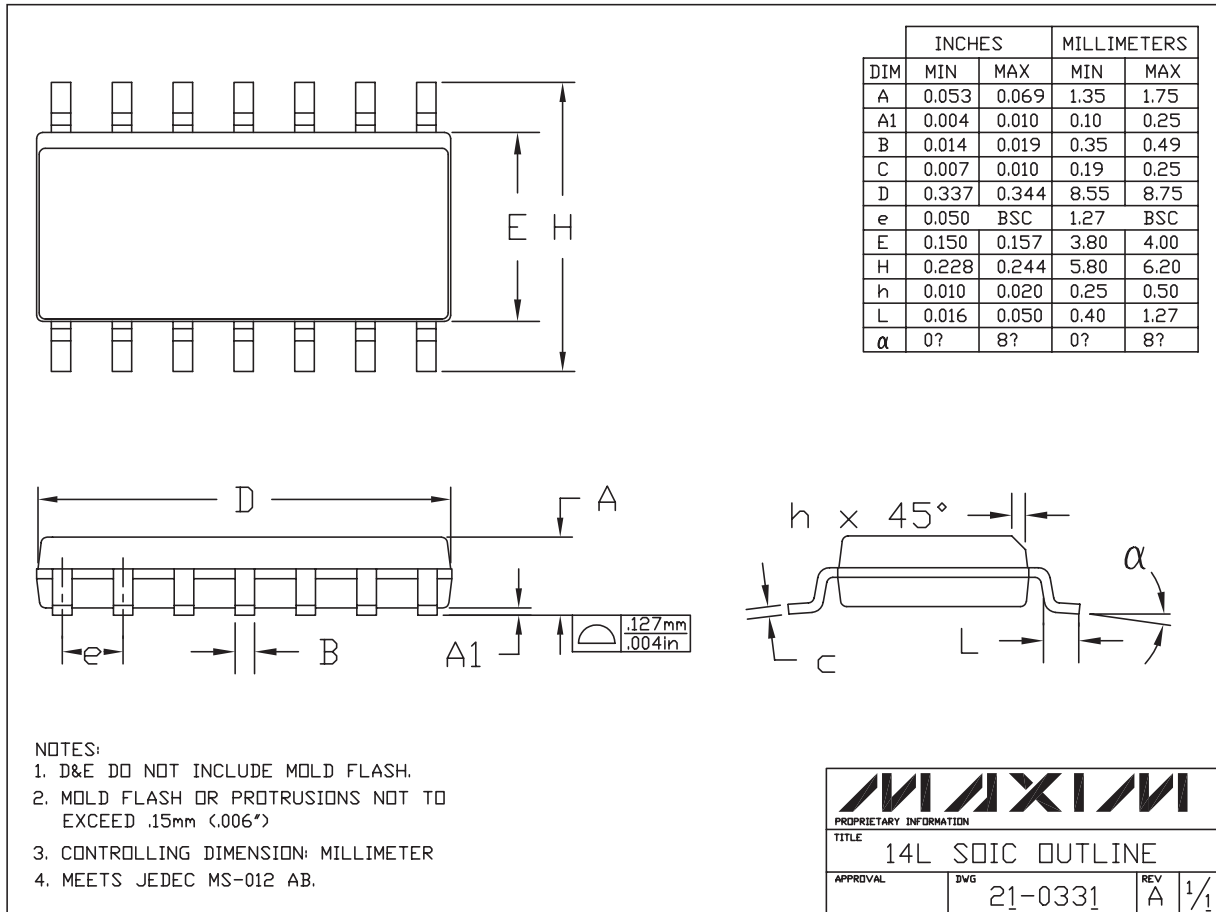

Maxim cannot assume responsibility for use of any circuitry other than circuitry entirely embodied in a Maxim product. No circuit patent licenses are implied. Maxim reserves the right to change the circuitry and specifications without notice at any time.

18 Maxim Integrated Products, 120 San Gabriel Drive, Sunnyvale, CA 94086 408-737-7600